

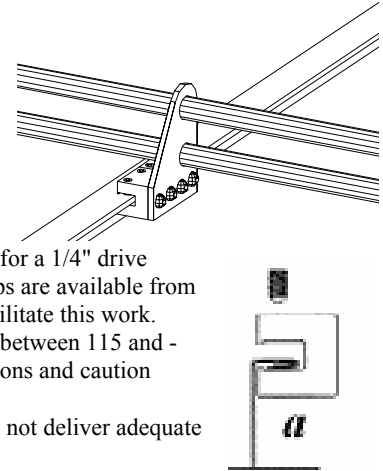

## Installation Instructions for #4000T Pipe Style Snowguards

### I. Bracket Installation

1. When attaching clamps to seams which are machine folded (regardless of panel profile and geometry), the S-5-U clamp is designed to engage the seam as shown for horizontal seam applications, set screws must be accessible from the top for tightening ("a"). ALL 4 SET SCREWS SHOULD BE IN THE SAME SIDE OF THE CLAMP
2. NOTE: Some horizontal seams may require additional hand crimping at the clamp location. Consult your S-5 distributor for crimping tool information.
3. Determine which side of the clamp to load the set screws into, and assemble all the set screws into the same side of the clamp, being careful that the bolt hole will be in the desired (upslope or downslope) orientation, with the set screws on the correct side of the seam.
4. Position the clamps appropriately on the panel seam. Using a 3/16" allen-wrench attachment tip for a 1/4" drive screwgun, tighten and retighten set screws as the seam material compresses. (These screwgun tips are available from your S-5 distributor). On low seam profiles, a 4" bit extension on the screwgun will facilitate this work. Most industrial grade screwguns are rated at 115 inch-pounds tightening torque and will deliver between 115 and - lbs (13-17Nm) at the *highest torque setting*. Please see ultimate load table for proper screw tensions and caution notes for various panel seams.
5. **CAUTION:** Battery-operated guns may not deliver consistent screw tension. Drywall guns may not deliver adequate tension.
6. Insert the 1" o.d. tubing through the holes in the uprights.
7. See Pipe Coupling Installation instructions for installing the 1" o.d. tubing.



### II. Locking Collars, End Caps, and Ice Flags (optional)

1. Locking collars (#65) should be placed over each end of each line of tubing. Center the tubing on the snowguards and tighten the set screw on the collar until it no longer slips.
2. End caps (#56) are installed by pressing the cap into the end of the pipe.
3. Ice flags (#95), if used, should be placed over the top tube so that the long leg rests against the uphill side of both tubes. Use the carriage bolt and nut to hold the ice flag in position.

\*Please note: If it is necessary to unassemble and reassemble the #4000 bracket, the bolts that hold the flag onto the bracket in the upper holes and the bolts in the lower holes are treaded differently.

The S-5! clamp is a handy gadget for a great many uses, but will not perform miracles.

PLEASE USE THIS PRODUCT RESPONSIBLY! Any loads imposed on the S-5!clamp will be transferred to the panels. Panels must be adequately attached to building structure to resist these loads. For critical installations, inquire for specific test data of ultimate tensile load on specific panel materials and seam types. When tabled values are used, screw tensions should be verified and factors of safety should be used as appropriate. The manufacturer expresses no opinions as to the suitability of the S-5! for any specific application or project condition.

ALWAYS PROVIDE WORKER FALL PROTECTION WHEN INSTALLING S-5!. THE S-5! CLAMP IS NOT APPROVED FOR USE AS A PERSONAL FALL RESTRAINT DEVICE Copyright © 2000, Metal Roof Innovations, Ltd.

## Snowguard Layout for Pipe Style Brackets

- \* Contact the manufacturer for detailed layout.
- \* Horizontal spacing between brackets should be 48" maximum. This may have to be decreased due to variable conditions.
- \* Do not install runs than 100 feet long without a break to allow for thermal expansion.
- \* First row of snowguards is installed above outer most wall or support of the building.
- \* Tubing is 1" O.D. aluminum.
- \* Brackets are made of aluminum and are available in other metals.
- \* One, two and three pipe systems are available.

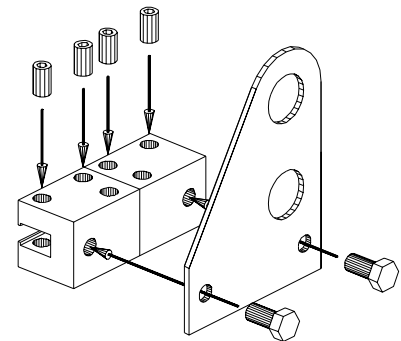

Document version 08.02.2004