



# ALPINE SNOWGUARDS

www.alpinesnowguards.com

289 Harrel Street  
 Morrisville, VT 05661  
 Toll Free Phone 1.888.766.4273  
 Toll Free Fax 1.888.766.9994  
 Web www.alpinesnowguards.com  
 E-mail info@alpinesnowguards.com

07 52 53 Snow Guards

**NOTES:**

1. INSTALLATION TO BE COMPLETED IN ACCORDANCE WITH MANUFACTURER'S SPECIFICATIONS.
2. DO NOT SCALE DRAWINGS.
3. CONTACT MANUFACTURER FOR DETAILED LAYOUT.

REVISIONS		
REV.	DESCRIPTION	DATE
A	Changed flag to bent design	3/3/2008

- |  |   |
|--|---|
| <input checked="" type="checkbox"/> DESIRED PIPE CONFIGURATION | <input checked="" type="checkbox"/> SELECT DESIRED FINISH |
| <input type="checkbox"/> 2 PIPE HI-HOLE                        | <input type="checkbox"/> MILL (STANDARD)                  |
| <input type="checkbox"/> 2 PIPE                                | <input type="checkbox"/> POWDER COAT                      |
|  | <input type="checkbox"/> ANODIZED                         |

**PIPE SYSTEM INCLUDES:**

- ICE FLAG
- END CAPS
- END COLLARS
- PIPE
- COUPLINGS

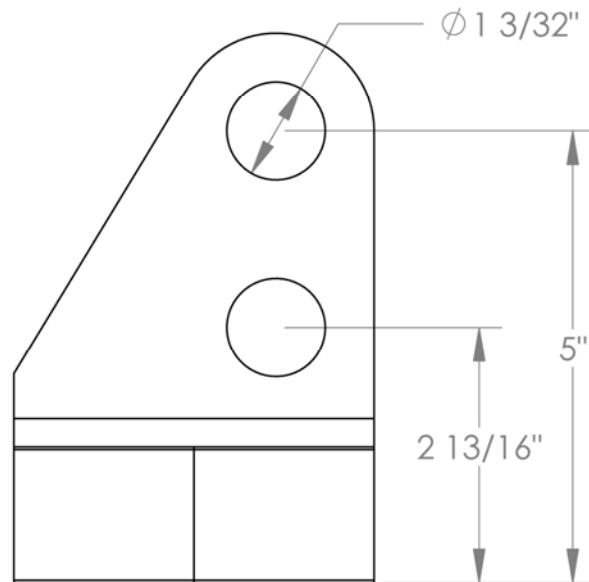
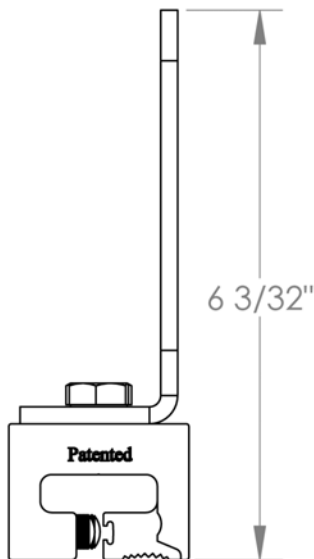
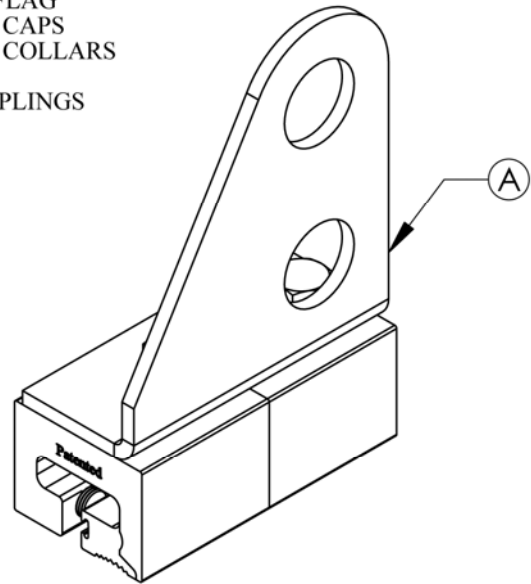
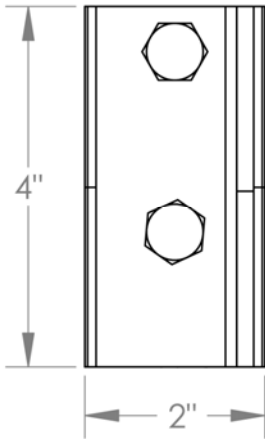

## #4000T2K Two-Pipe Clamp to the Seam Snow Guard for Standing Seam Metal Roofs



## #4000T2K Snow Guard Specification Sheet

### PART 1 - GENERAL

#### 1.1 SUMMARY

##### A. WORK INCLUDES

1. #4000T2K Snow guard that does not penetrate the roof using S-5! Technology.
2. Provide appropriate snow guard and fasteners for the roof system.

##### B. RELATED SECTIONS

1. Section 07600: Flashing and Sheet Metal. MasterFormat™ 2004 07 60 00
2. Section 07610: Metal Roofing MasterFormat™ 2004 07 61 00
3. Division 7: Thermal and Moisture Protection.

#### 1.2 SYSTEM DESCRIPTION

##### A. COMPONENTS:

1. #4000T2K snow guard system consists of snow guard block and flag assembly and set screws.
2. Aluminum tubing.
3. Couplings.
4. End Plugs (optional).
5. Ice Flags (optional).
6. End Collars (optional).

##### B. DESIGN REQUIREMENTS:

1. Spacing to be recommended by manufacturer or building engineer.
2. Uses 4 set screws per snow guard.
3. It is important to design new structures or assess existing structures to make sure that they can withstand retained snow loads.

1.3 SUBMITTAL - Submit manufacturer's specifications, standard detail drawings, recommended layout and installation instructions.

1.4 QUALITY ASSURANCE - Installer to be experienced in the installation of specified roofing material and snow guards for not less than 5 years in the area of the project.

DELIVERY / STORAGE / HANDLING - Inspect material upon delivery and order replacements for any missing or defective items. Keep material dry, covered and off the ground until installed.

### PART 2 - PRODUCTS

#### 2.1 MANUFACTURER

- A. Alpine SnowGuards. A division of Vermont Slate & Copper Services Inc., 289 Harrell St, Morrisville, VT (888) 766-4273.

#### 2.2 MATERIALS

- A. Snow guard Block and Flag are extruded and milled 6061-T6 Aluminum.
- C. Tubing is 6061-T6, 1" outside diameter and 1/8" wall thickness extruded Aluminum.
- D. Couplings are 2011 Aluminum 3" long.
- E. End Caps are 302 stainless steel.
- F. Ice Flags are 6061-T6 Aluminum 3" x \_\_\_" (as needed).
- G. End Collars are 6061-T6 Aluminum.
- H. Fasteners are 304 Stainless Steel with an 18-8 finish.

2.3 FINISH - All materials provided mill finish. Coatings available upon request.

### PART 3 - EXECUTION

#### 3.1 EXAMINATION

- A. Substrate: Inspect roof system to be properly attached and installed to withstand additional loading incurred. Notify General Contractor of any deficiencies before installing Alpine SnowGuards.

#### 3.2 INSTALLATION

- A. Comply with architectural drawings for location and with Manufacturer's instructions for installation.

## #4000T2K Two-Pipe Clamp to the Seam Snow Guard for Standing Seam Metal Roofs



## Installation Instructions for #4000T2K Pipe Style Snow Guards

### I. Bracket Installation

1. The S-5-Z2K clamp is designed to engage the seam as shown.
2. Determine which side of the clamp to load the set screws into, and assemble both set screws into the same side of the clamp, being careful that the bolt hole will be in the desired (upslope or downslope) orientation, with the set screws on the correct side of the seam.
3. Position the clamps appropriately on the panel seam. Using a 3/16" allen-wrench attachment tip for a 1/4" drive screwgun, tighten and retighten set screws as the seam material compresses. (These screwgun tips are available from your S-5! product distributor). On low seam profiles, a 4" bit extension on the screwgun will facilitate this work. Most industrial grade screwguns are rated at 115 inch-pounds tightening torque and will deliver between 115 and -lbs (13-17Nm) at the *highest torque setting*. Please see ultimate load table on the back of this page or attached page for proper screw tensions and caution notes for various panel seams.
4. **CAUTION:** Battery-operated guns may not deliver consistent screw tension. Drywall guns may not deliver adequate tension.
5. Insert the 1" o.d. tubing through the holes in the uprights.
6. See Pipe Coupling Installation instructions for installing the 1" o.d. tubing.

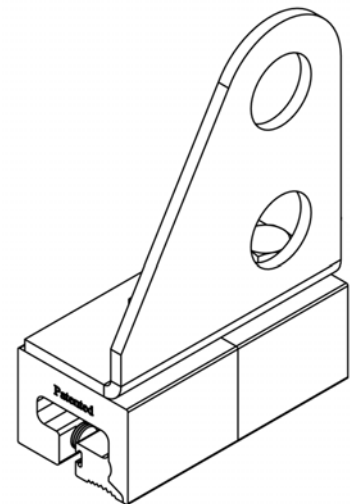
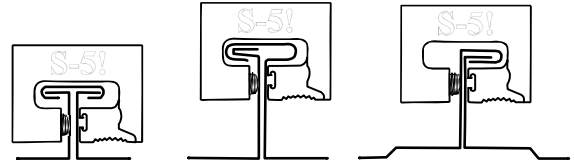

### II. Locking Collars, End Caps, and Ice Flags (optional)

1. Locking collars (#65 ) should be placed over each end of each line of tubing. Center the tubing on the snow guards and tighten the set screw on the collar until it no longer slips.
2. End caps (#56) are installed by pressing the cap into the end of the pipe.
3. Ice flags (#95 ), if used, should be placed over the top tube so that the long leg rests against the uphill side of both tubes. Use the carriage bolt and nut to hold the ice flag in position.

### III. Bracket Assembly – to the right is an assembly detail for the #4000T2K brackets.

The S-5! clamp is a handy gadget for a great many uses, but will not perform miracles. **PLEASE USE THIS PRODUCT RESPONSIBLY!** Any loads imposed on the S-5!clamp will be transferred to the panels. Panels must be adequately attached to building structure to resist these loads. For critical installations, inquire for specific test data of ultimate tensile load on specific panel materials and seam types. When tabled values are used, screw tensions should be verified and factors of safety should be used as appropriate. The manufacturer expresses no opinions as to the suitability of the S-5! for any specific application or project condition.

**ALWAYS PROVIDE WORKER FALL PROTECTION WHEN INSTALLING S-5!. THE S-5! CLAMP IS NOT APPROVED FOR USE AS A PERSONAL FALL RESTRAINT DEVICE**

Copyright © 2007, Metal Roof Innovations, Ltd.

### Snow Guard Layout for Pipe Style Brackets

- \* Contact the manufacturer for detailed layout.
- \* Horizontal spacing between brackets should be 48" maximum. This may have to be decreased due to variable conditions.
- \* Do not install runs than 100 feet long without a break to allow for thermal expansion.
- \* First row of snow guards is installed above outer most wall or support of the building.
- \* Tubing is 1" O.D. aluminum.
- \* Brackets are made of aluminum and are available in other metals.
- \* One, two and three pipe systems are available.

## #4000T2K Two-Pipe Clamp to the Seam Snow Guard for Standing Seam Metal Roofs



# ALPINE SNOWGUARDS

www.alpinesnowguards.com

Toll Free Fax 1.888.766.9994

289 Harrel Street  
Morrisville, VT 05661

Toll Free Phone 1.888.766.4273

Web www.alpinesnowguards.com

E-mail info@alpinesnowguards.com

07 52 53 Snow Guards

**NOTES:**

1. INSTALLATION TO BE COMPLETED IN ACCORDANCE WITH MANUFACTURER'S SPECIFICATIONS.
2. DO NOT SCALE DRAWINGS.
3. CONTACT MANUFACTURER FOR DETAILED LAYOUT.

REVISIONS		
REV.	DESCRIPTION	DATE
A	Changed flag to bent design	3/3/2008

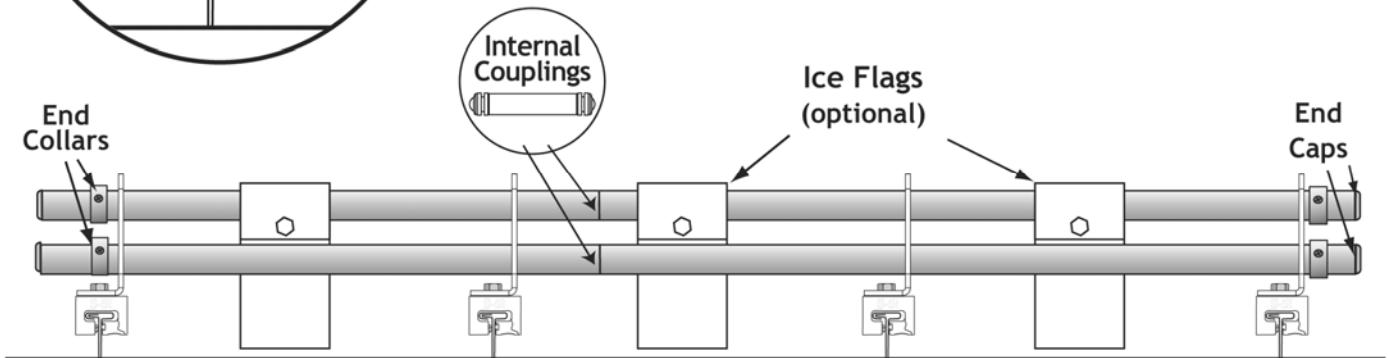
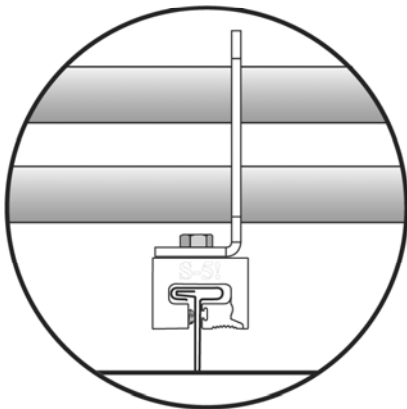
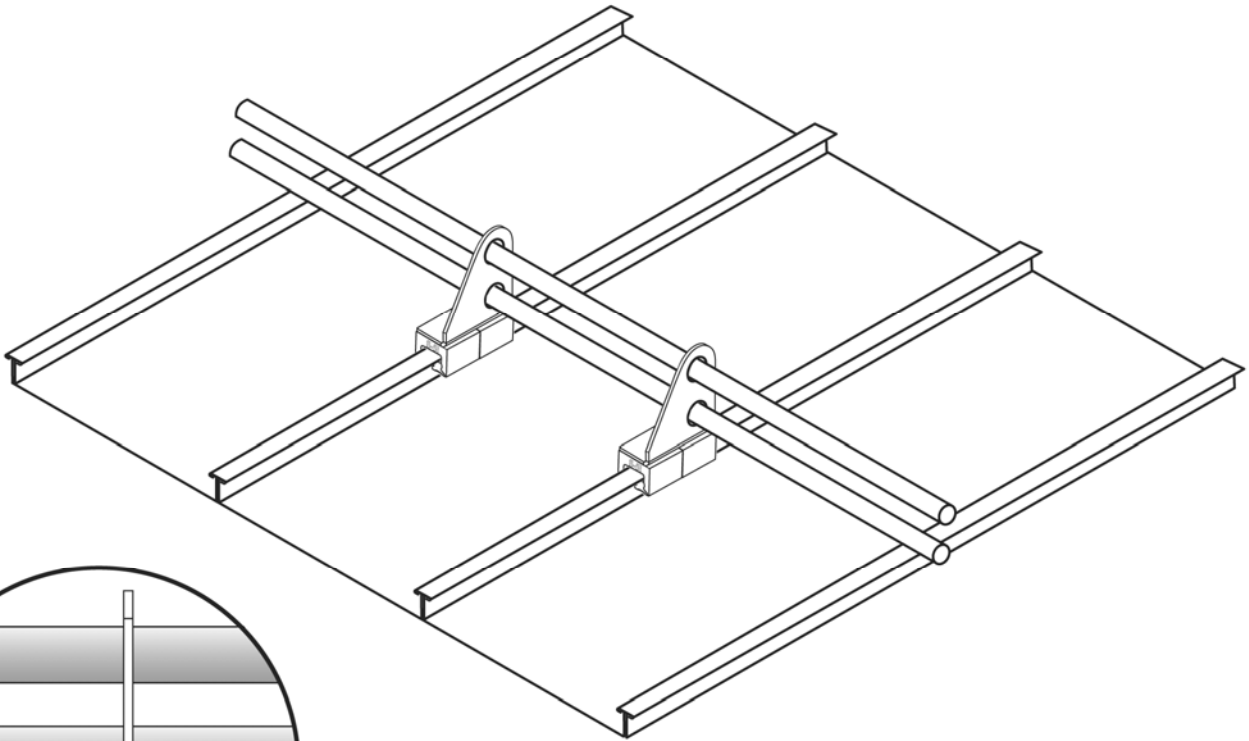

## #4000T2K Two-Pipe Clamp to the Seam Snow Guard for Standing Seam Metal Roofs