



**ALPINE
SNOWGUARDS™**
www.alpinesnowguards.com

Alpine SnowGuards
289 Harrel Street
Morrisville, VT 05661
Toll Free Phone 1.888.766.4273
Toll Free Fax 1.888.766.9994
Web www.alpinesnowguards.com
E-mail info@alpinesnowguards.com

07 52 53 Snow Guards

NOTES:

1. SNOW GUARDS TO BE INSTALLED ACCORDING TO MANUFACTURER'S SPECIFICATIONS.
2. DO NOT SCALE DRAWINGS.
3. CONTACT MANUFACTURER FOR CUSTOM MATERIALS AND COLORS.
4. CONTACT MANUFACTURER FOR SUGGESTED LAYOUT.

REVISIONS		
REV.	DESCRIPTION	DATE
A	CHANGE DIRECTION OF SNOW PAD	01/01/06
B	NEW GUSSET DESIGN	6/19/2006

- MATERIAL
- COPPER
 - ZINC
 - LEAD-COATED COPPER
 - ALUMINUM
 - POWDER COAT
 - PAINTED
 - MILL FINISH
 - FREEDOM GRAY
 - GALVALUME
 - POWDER COAT
 - MILL FINISH

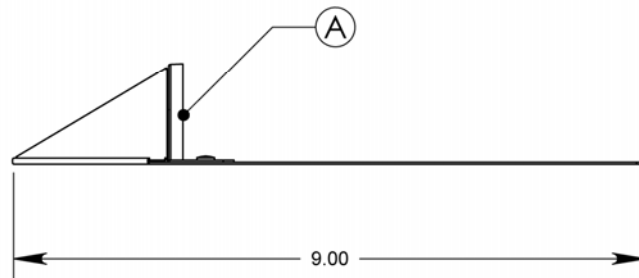
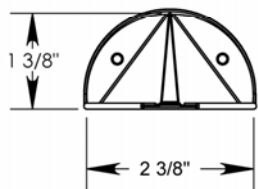
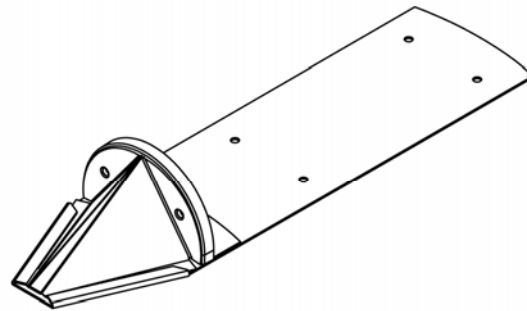
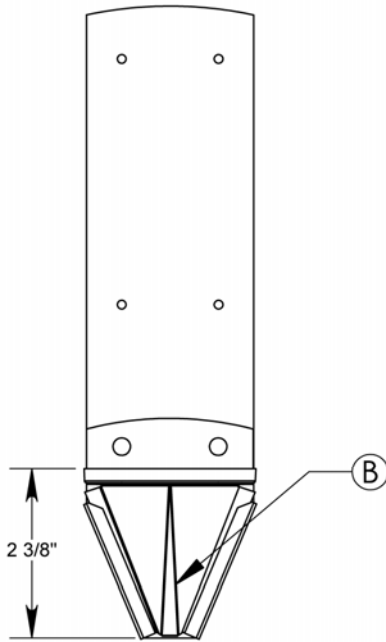

#40 Half-Round Pad-Style Snow Guard for Composition Shingles



#40 Snow Guard Specification Sheet

PART 1 - GENERAL

1.1 SUMMARY

A. WORK INCLUDES

1. #40 Gusseted snow guard that attaches directly to the roof deck.
2. Coordinate with the installation of the roof to assure proper placement of the snow guards.
3. Provide appropriate snowguard and fasteners for the roof system.

B. RELATED SECTIONS

- | | | |
|-------------------|----------------------------------|-----------------------------|
| 1. Section 07600: | Flashing and Sheet Metal. | MasterFormat™ 2004 07 60 00 |
| 2. Section 07310: | Roofing Shingles and Shakes | MasterFormat™ 2004 07 31 00 |
| 3. Section 07320: | Roofing Tiles | MasterFormat™ 2004 07 32 00 |
| 4. Division 7: | Thermal and Moisture Protection. | |

1.2 SYSTEM DESCRIPTION

A. COMPONENTS:

1. #40 Snowguard system consists of individual metal snowguards.
2. Fasteners
 - a. To be of metal compatible with snowguards.
 - b. Fasteners should be selected for compatibility with roof deck.
 - c. All snowguards must be mechanically fastened to the roof deck.

B. DESIGN REQUIREMENTS:

1. Spacing to be recommended by manufacturer or building engineer.
2. Minimum 2 fasteners per snowguard.
3. It is important to design new structures or assess existing structures to make sure that they can withstand retained snow loads.

1.3 SUBMITTAL - Submit manufacturer's specifications, standard detail drawings, and recommended layout and installation instructions.

1.4 QUALITY ASSURANCE - Installer to be experienced in the installation of specified roofing material and snowguards for not less than 5 years in the area of the project.

1.5 DELIVERY / STORAGE / HANDLING - Inspect material upon delivery and order replacements for any missing or defective items. Keep material dry, covered and off the ground until installed.

PART 2 - PRODUCTS

2.1 MANUFACTURER

- A. Alpine SnowGuards. A division of Vermont Slate & Copper Services Inc., 289 Harrell St, Morrisville, VT (888) 766-4273.

2.2 MATERIALS (choose one)

- A. Copper Strap, hood and gusset are 16 oz. C.R. copper.
- B. Lead-coated Copper Strap, hood and gusset are 16 oz. C.R. copper, lead-coated and cut to size.
- C. Galvalume Strap, hood and gusset are 24 ga. Galvalume.
- D. Aluminum Strap, hood and gusset are .032 Aluminum.
- E. Freedom Gray strap, hood and gusset are 16 oz. C.R. copper, coated and cut to size.
- F. Other (specify)

2.3 FINISH

- A. Mill finish.
- B. Powder coated
- C. Kynar™ 500 or Hylar™ 5000 pre-painted sheet (aluminum only).

PART 3 - EXECUTION

3.1 EXAMINATION

- A. Substrate: Inspect roof system to be properly attached and installed to withstand additional loading incurred. Notify General Contractor of any deficiencies before installing Alpine SnowGuards.

3.2 INSTALLATION

- A. Comply with architectural drawings for location and with Manufacturer's instructions for installation.

#40 Half-Round Pad-Style Snow Guard for Composition Shingles

Pad Style Snow Guard Placement Less Than 75 psf Snow Load

On Composition Shingle Roofs with a 75 psf or Less Design Load and a 6/12 or Less Roof Pitch

If your roof has the above conditions, you only need the three-row pattern along the eave regardless of the rafter length. If your roof does not meet either of the conditions, i.e. if the Building Design Load is more than 75 psf or if the roof pitch is more than 6/12, use the layouts listed on the following pages.

Ridge/Peak

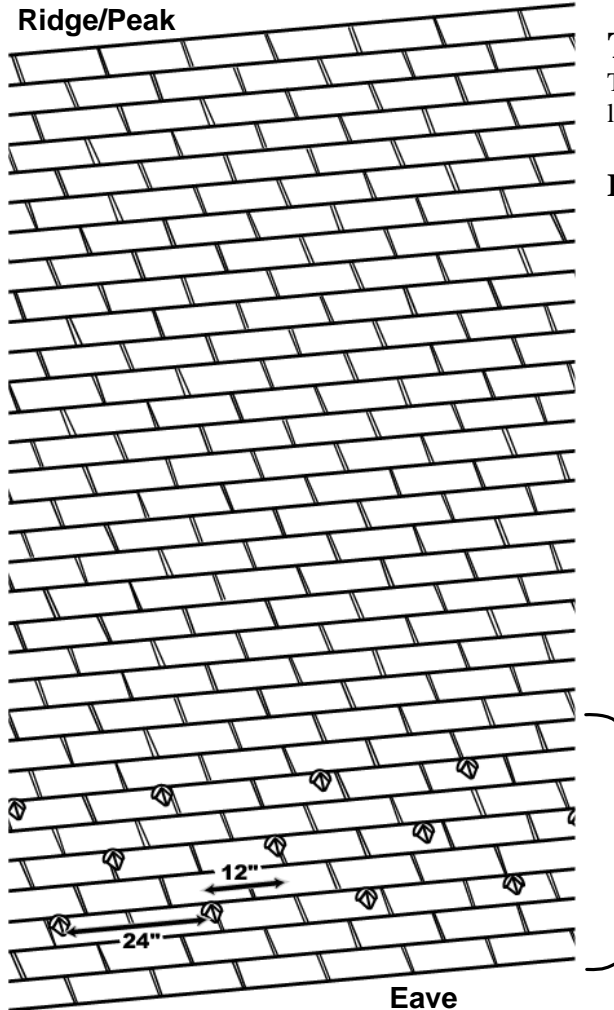

Three-Row Pattern

The three-row pattern uses 17 snow guards for every 10' of eave. (eave length (in feet) X 1.7 = qty. needed).

Installation

1. The third row of shingles is installed in the usual manner.
2. The snow guard is placed on the shingle low enough so that the next course of shingles lies properly over the top of the snow guard. The top of the cap should be 5/8" below the bottom of the next row of shingles.
3. Horizontal spacing is 24" on center.
4. Use two fasteners of compatible material on each snow guard. The fasteners are inserted into the two holes on the snow guard strap and through the shingle into the roof deck.
5. Install two more rows of shingles and then install another row of snow guards offset 12" horizontally from the first row.
6. Install two more rows of shingles and then the third row of snow guards. You should have the diagonal pattern pictured.

Standard Three-Row Pattern

24" on center horizontally, 2 courses of shingles vertically, with the second row offset 12"

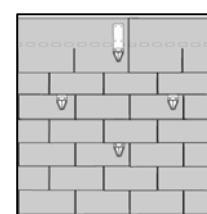
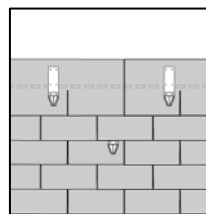
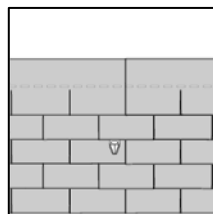
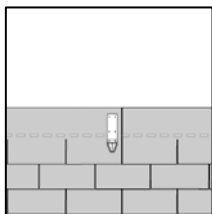

#40 Half-Round Pad-Style Snow Guard for Composition Shingles

#40 Pad Style Snow Guard Placement Less Than 75 psf Snow Load

On Composition Shingle Roofs with a 75 psf or Less Design Load and a More Than 6/12 Pitch

The image below shows a sample installation of a roof with a rafter length greater than 15', a roof pitch of 24/12 or less and a Building Design Load of less than 75 psf. All snow guard installations must have the standard three-row pattern along the eave. Remaining snow guards should be evenly spaced between the top of the three-row pattern to within 10' of the ridge. If the rafter length is less than 15' you only need the three-row pattern which requires 17 snow guards per 10' of eave.

12

If the Building Design Load is less than 75 psf and the roof pitch is less than 24/12, but more than 6/12, you will need 12 snow guards per square using the 2X4 layout.

Installation Instructions for #40 Pad Style Snow Guard

1. The third row of shingles is installed in the usual manner.
2. The snow guard is placed on the shingle low enough so that the next course of shingles lies properly over the top of the snow guard. The top of the cap should be 5/8" below the bottom of the next row of shingles.
3. Horizontal spacing is 24" on center.
4. Use two fasteners of compatible material on each snow guard. The fasteners are inserted into the two holes on the snow guard strap and through the shingle into the roof deck.
5. Install two more rows of shingles and then install another row of snow guards offset 12" horizontally from the first row.
6. Supplemental rows are installed at 48" on center horizontally and 3 courses of shingles vertically.
7. Repeat these steps for the entire snow guard layout.

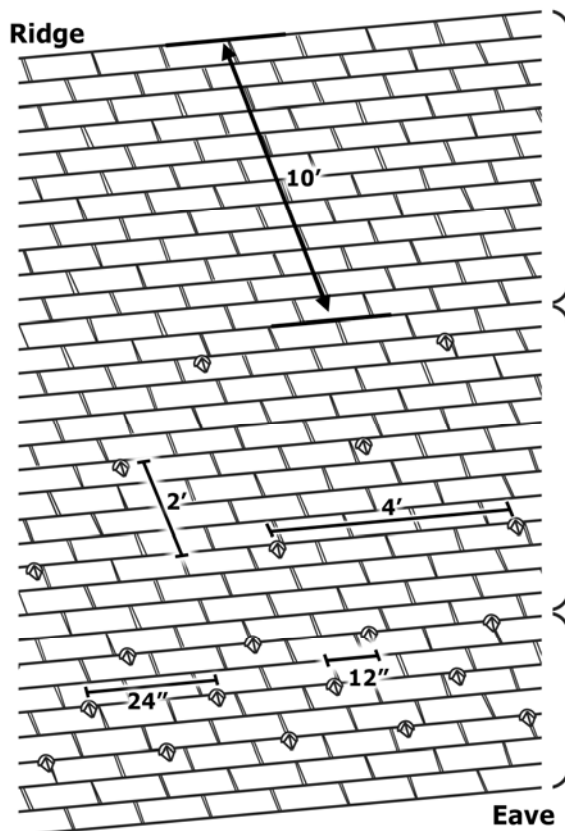

2 X 4 Layout – less than 75 psf Building Design Load and less than 24/12 roof pitch using 12 snow guards per square.

Top ten feet of rafter does not generally require snow guards except in extreme snow load areas.

2 X 4 Supplemental Pattern

This pattern is for installations using 12 snow guards per square including the standard three-row pattern. Space rows 2' vertically and 4' horizontally to within 10' of the ridge.

Standard Three-Row Pattern - for all roofs. Three rows 24" on center horizontally with the middle row staggered 12".

#40 Half-Round Pad-Style Snow Guard for Composition Shingles

Pad Style Snow Guard Placement for Extreme Snow Areas Greater Than 75 psf Design Load

Most snow guard installations will use 12 snow guards per square with our standard 2 X 4 layout. If your project is in an extreme snow area, greater than 75 psf you will need to use one of these layouts. If your Design Load is between 75 psf and 110 use the 2 X 3 layout. If your Design Load is from 111 psf to 150 psf use the 2 X 2 layout.



Installation Instructions for #10 Pad Style Snow Guard on Roofs

1. The third row of shingles is fastened to the roof in the usual manner.
2. The snow guard is placed on the shingle with the up slope end of the strap resting on the roof deck above the shingle. The snow guard pad should be placed low enough on the shingle so that the next course of shingles, course 4 lays properly over the top of the snow guards, and the pad is set 3 times the thickness of the shingle below the next course. Horizontal spacing should be 24" on center for the first three courses.
3. Two nails or screws of the same or compatible material as the snow guard are inserted through the two holes at the top of the strap to secure the snow guard to the roof deck.
4. Repeat these steps for the entire snow guard layout.

2 X 3 Pattern - for roofs 76 psf to 110 psf, 17 to 21 snow guards per square

2 X 2 Pattern - for roofs 111 psf to 150 psf, about 22 to 27 snow guards per square

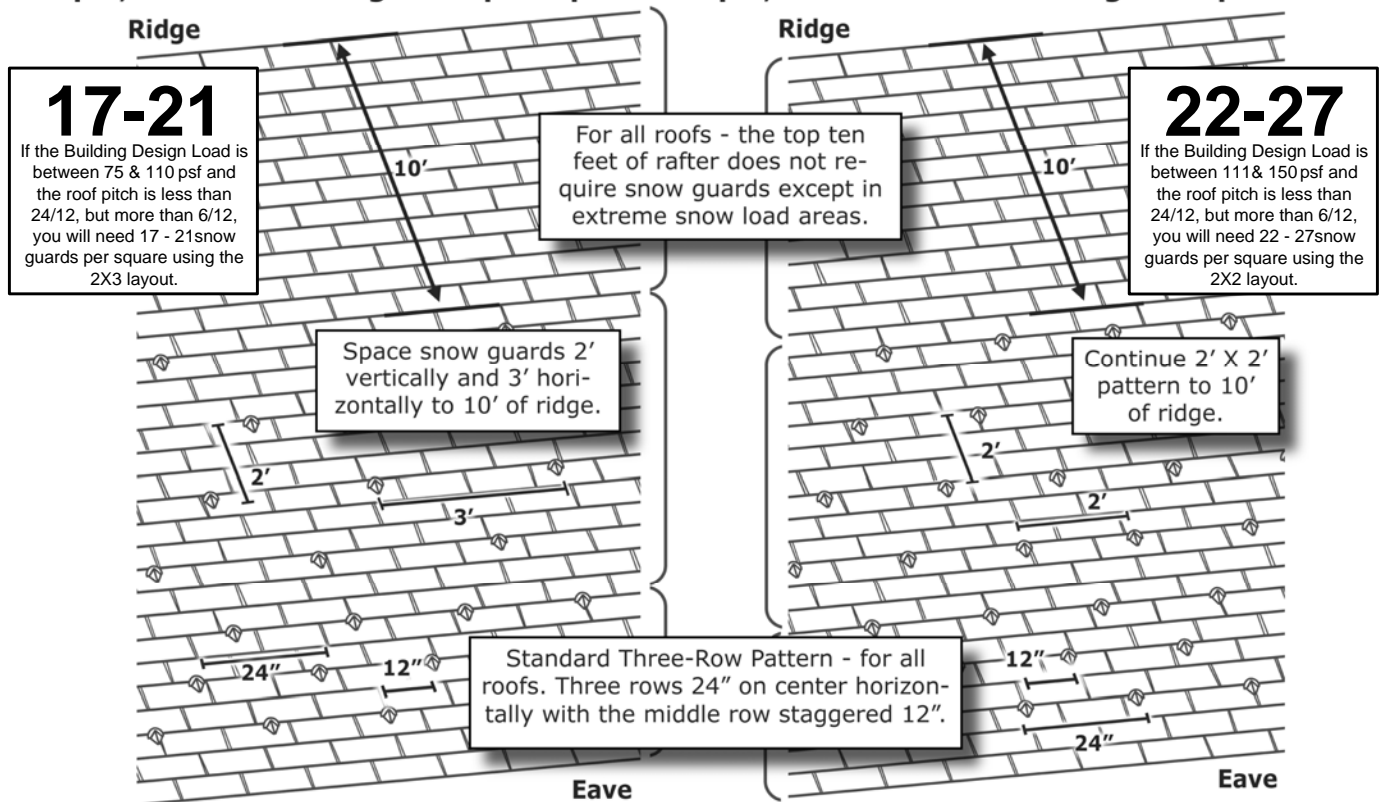

#40 Half-Round Pad-Style Snow Guard for Composition Shingles