

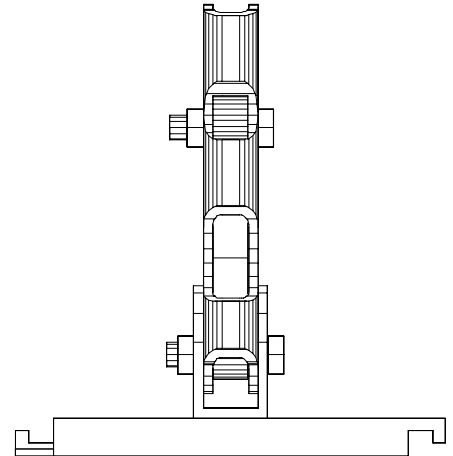

# ALPINE SNOWGUARDS

A Division of Vermont Slate & Copper Services, Inc.

Web [www.alpinesnowguards.com](http://www.alpinesnowguards.com)  
E-mail [info@alpinesnowguards.com](mailto:info@alpinesnowguards.com)  
Toll Free Phone 1.888.766.4273  
Toll Free Fax 1.888.766.9994  
289 Harrell Street, Morrisville, VT 05661

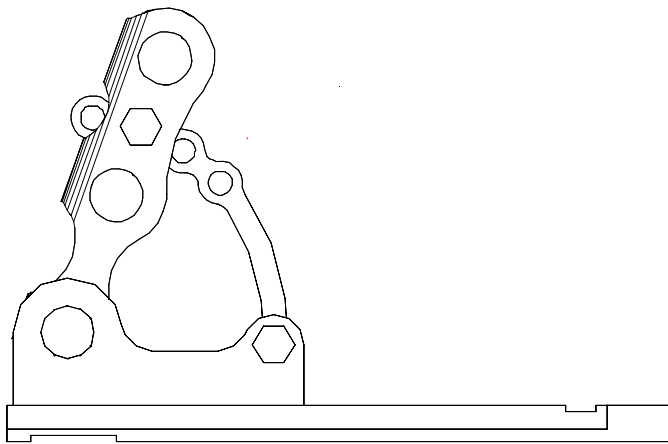
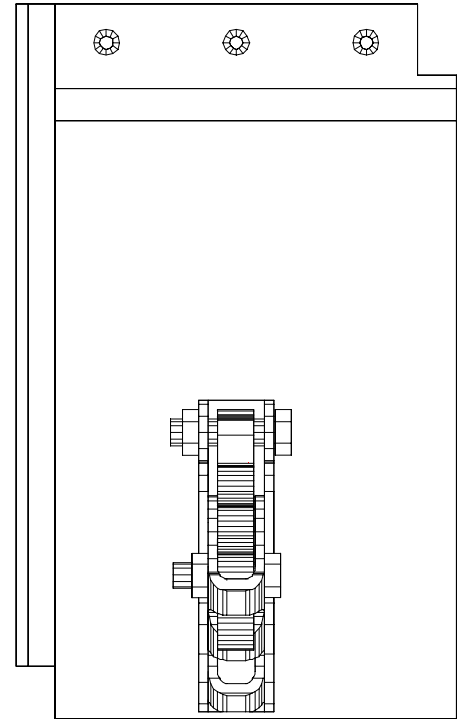
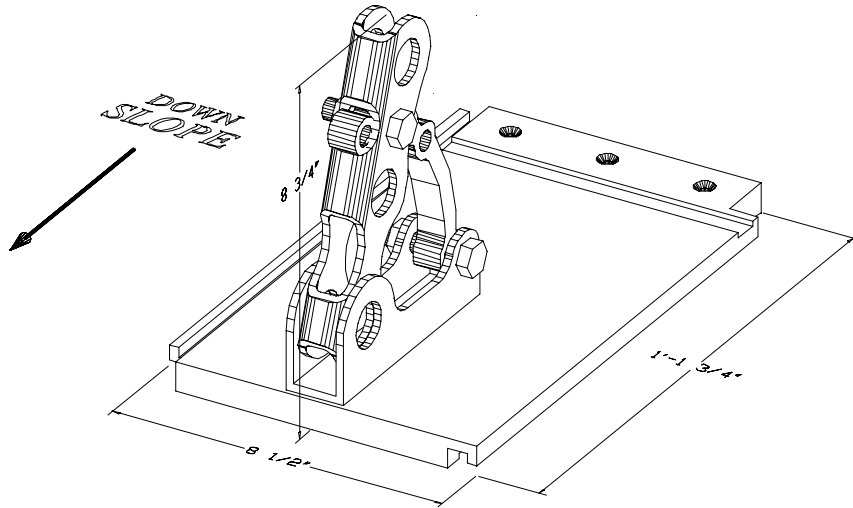

## #235LF Snow Guard Bracket for Interlocking Tile

Patent # D430005, D428799 and D426453

Document version 08.02.2004



# ALPINE SNOWGUARDS

A Division of Vermont Slate & Copper Services, Inc.

Web [www.alpinesnowguards.com](http://www.alpinesnowguards.com)

E-mail [info@alpinesnowguards.com](mailto:info@alpinesnowguards.com)

Toll Free Phone 1.888.766.4273

Toll Free Fax 1.888.766.9994

289 Harrell Street. Morrisville, VT 05661

## **Assembly Instructions for #235LF Pipe Style Snowguards**

### I. For **bolt down** style brackets on tile roofs.

1. Brackets should be mounted onto the plate (using the hex bolts) before the plate has been screwed or bolted to the roof deck.
2. Consult with an engineer or fastener company to determine the fastener required to attach the base plate to the wood block. Fasteners must exceed 2000 pounds sheer combined.
3. Plates should be securely bolted or screwed to the roof in place of a tile.
4. Insert tubing through the holes in the uprights.

### II. Locking Collars, End Caps, and Ice Flags (optional )

1. Locking collars ( #65 ) should be placed over each end of each line of tubing. Center the tubing on the snowguards and tighten the set screw on the collar until it no longer slips.
2. End caps ( #56 ) are installed by pressing the cap into the end of the pipe.
3. Ice flags ( #95 ), if used, should be placed over the top tube so that the long leg rests against the uphill side of both tubes. Use the carriage bolt and nut to hold the ice flag in position.

### **Snowguard Layout for Pipe Style Brackets**

- \* Contact the manufacturer for detailed layout.
- \* Horizontal spacing between brackets should be 48" maximum. This may have to be decreased due to variable conditions.
- \* Do not install runs than 100 feet long without a break to allow for thermal expansion.
- \* First row of snowguards is installed above outer most wall or support of the building.
- \* Tubing is 1" O.D. aluminum.
- \* Brackets are made of aluminum and are available in other metals.

Document version 08.02.2004



# ALPINE SNOWGUARDS

A Division of Vermont Slate & Copper Services, Inc.

Web [www.alpinesnowguards.com](http://www.alpinesnowguards.com)

E-mail [info@alpinesnowguards.com](mailto:info@alpinesnowguards.com)

Toll Free Phone 1.888.766.4273

Toll Free Fax 1.888.766.9994

289 Harrell Street. Morrisville, VT 05661

## #235LF Snowguard Specification Sheet

### **PART 1 - GENERAL**

#### 1.1 SUMMARY

##### A. WORK INCLUDES

1. #235LF Snowguard that attaches directly to the roof deck.
2. Provide appropriate snowguard and fasteners for the roof system.

##### B. RELATED SECTIONS

1. Section 07600: Flashing and Sheet Metal.
2. Section 07310: Shingles.
3. Section 07320: Roofing Tiles.
4. Division 7: Thermal and Moisture Protection.

#### 1.2 SYSTEM DESCRIPTION

##### A. COMPONENTS:

1. #235LF Snowguard system consists of:
  - a. Snowguard bracket.
  - b. Base plate with 2 threaded studs for attaching snowguard assembly.
2. Aluminum tubing.
3. Threaded Couplings.
4. End Caps (optional).
5. End Collars (optional).
6. Fasteners
  - a. To be of metal compatible with snowguards.
  - b. Fasteners should be selected for compatibility with the roof deck.
  - c. Fastener strength should exceed or be equal to that of the snowguard system.

##### B. DESIGN REQUIREMENTS:

1. Spacing to be recommended by manufacturer or building engineer.
2. Minimum 4 fasteners per snowguard.
3. It is important to design new structures or assess existing structures to make sure that they can withstand retained snow loads.

1.3 SUBMITTAL - Submit manufacturer's specifications, standard detail drawings, recommended layout and installation instructions.

1.4 QUALITY ASSURANCE - Installer to be experienced in the installation of specified roofing material and snowguards for not less than 5 years in the area of the project.

1.5 DELIVERY / STORAGE / HANDLING - Inspect material upon delivery and order replacements for any missing or defective items. Keep material dry, covered and off the ground until installed.

### **PART 2 - PRODUCTS**

#### 2.1 MANUFACTURER

- A. Alpine SnowGuards. A division of Vermont Slate & Copper Services Inc., P.O. Box 430, Stowe, VT (888) 766-4273.

#### 2.2 MATERIALS

- A. Snowguard Bracket and base plate are extruded and milled 6061-T6 Aluminum
- B. Tubing is 6005-T5, 1" outside diameter and 1/8" wall thickness extruded Aluminum.
- C. Threaded Couplings are 6061-T6 Aluminum 5" long.
- D. End Caps are 302 stainless steel.
- E. End Collars are 6061 T-6 aluminum shaft collars.
- F. Fasteners are 302 or 304 Stainless Steel.

2.3 FINISH - All materials provided mill finish.

### **PART 3 - EXECUTION**

#### 3.1 EXAMINATION

- A. Substrate: Inspect roof system to be properly attached and installed to withstand additional loading incurred. Notify General Contractor of any deficiencies before installing Alpine SnowGuards.

#### 3.2 INSTALLATION

- A. Comply with architectural drawings for location and with Manufacturer's instructions for installation.

Document version 08.02.2004



# ALPINE SNOWGUARDS

A Division of Vermont Slate & Copper Services, Inc.

Web [www.alpinesnowguards.com](http://www.alpinesnowguards.com)

E-mail [info@alpinesnowguards.com](mailto:info@alpinesnowguards.com)

Toll Free Phone 1.888.766.4273

Toll Free Fax 1.888.766.9994

289 Harrell Street. Morrisville, VT 05661

## #235 LF Brass Snow Guard Specification Sheet

### PART 1 - GENERAL

#### 1.1 SUMMARY

##### A. WORK INCLUDES

1. #235 LF Snow guard that attaches directly to the roof deck.
2. Provide appropriate snowguard and fasteners for the roof system.

##### B. RELATED SECTIONS

1. Section 07600: Flashing and Sheet Metal.
2. Division 7: Thermal and Moisture Protection.

#### 1.2 SYSTEM DESCRIPTION

##### A. COMPONENTS:

1. #235 LF Snow guard system consists of :
  - a. Snowguard bracket assembly.
  - b. Base plate with 2 threaded studs for attaching snowguard assembly.
1. Tubing.
2. Couplings.
3. End Plugs (optional).
4. End Collars. (optional)
5. Fasteners
  - a. To be of metal compatible with snowguards.
  - b. Fasteners should be selected for compatibility with the roof deck.
  - c. Fastener strength should exceed or be equal to that of the snowguard system.

##### B. DESIGN REQUIREMENTS:

1. Horizontal spacing not to exceed 48".
2. Minimum 4 fasteners per snowguard.
3. It is important to design new structures or assess existing structures to make sure that they can withstand retained snow loads.

1.3 SUBMITTAL - Submit manufacturer's specifications, standard detail drawings, recommended layout and installation instructions.

1.4 QUALITY ASSURANCE - Installer to be experienced in the installation of specified roofing material and snowguards for not less than 5 years in the area of the project.

1.5 DELIVERY / STORAGE / HANDLING - Inspect material upon delivery and order replacements for any missing or defective items. Keep material dry, covered and off the ground until installed.

### PART 2 - PRODUCTS

#### 2.1 MANUFACTURER

A. Alpine SnowGuards. A division of Vermont Slate & Copper Services Inc., P.O. Box 430, Stowe, VT (888) 766.4273.

#### 2.2 MATERIALS

- A. Snowguard Bracket B260 Half Hard Brass
- B. Base Plate is 260 Half Hard Brass.
- C. Tubing is 330 Hard Drawn, 1" outside diameter and 1/8" wall thickness Brass.
- D. Couplings are 330 Hard Drawn 5" long.
- E. End Caps are brass plated 302 stainless steel.
- F. End Collars are cast bronze 1/4" thick.
- G. Fasteners are Brass.

2.3 FINISH - All materials provided mill finish.

### PART 3 - EXECUTION

#### 3.1 EXAMINATION

A. Substrate: Inspect roof system to be properly attached and installed to withstand additional loading incurred. Notify General Contractor of any deficiencies before installing Alpine SnowGuards.

#### 3.2 INSTALLATION

A. Comply with architectural drawings for location and with Manufacturer's instructions for installation.

Document version 08.02.2004



## Installation of #86 Pipe Coupling

Couplings come assembled and ready for application. If they come unassembled or loosened during shipping then assemble as per the detail below. **DO NOT OVERTIGHTEN** prior to inserting the coupling into the #75 tubing. Overtightening the bolt will cause the gasket to expand and make installation of the coupling difficult.

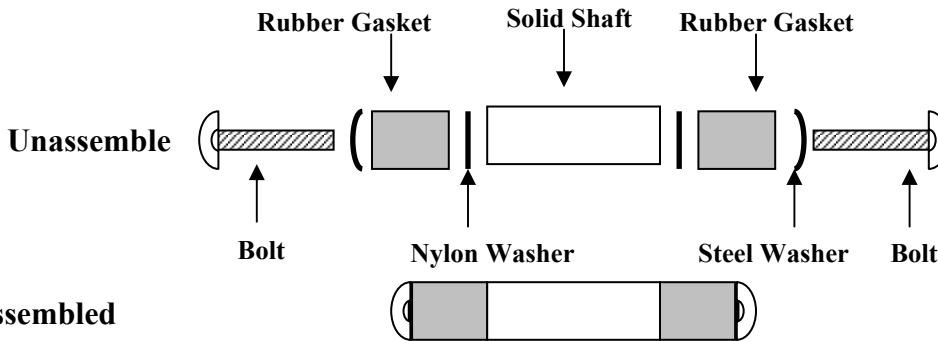

1. Insert assembled coupling into the end of one pipe so that half of the solid aluminum shaft is inserted.
2. Begin twisting the exposed half of the coupling in a clock-wise motion until the rubber gasket engages the pipe. Continue to tighten until the coupling can not be easily pulled out of the pipe.

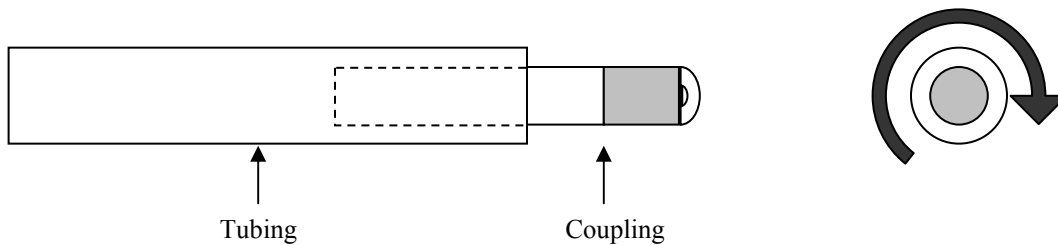

3. Slide next section of tubing over the exposed half of the coupling. Begin twisting the tubing in a clock-wise motion until the rubber gasket engages the pipe. Continue to tighten until the tubing can not be easily pulled off of the coupling.
4. If the system needs to be unassembled, simply turn the tubing counter clockwise until the coupling disengages. Then turn the coupling's solid shaft counter clockwise until it disengages from the tubing.

