

## Installation Instructions for #2000T2K Pipe Style Snow Guards

### I. Bracket Installation

1. The S-5-T2K clamp is designed to engage the seam.
2. ALL 2 SET SCREWS SHOULD BE IN THE SAME SIDE OF THE CLAMP
3. NOTE: Some horizontal seams may require additional hand crimping at the clamp location. Consult your S-5! distributor for crimping tool information.
4. Determine which side of the clamp to load the set screws into, and assemble both set screws into the same side of the clamp, being careful that the bolt hole will be in the desired (upslope or downslope) orientation, with the set screws on the correct side of the seam.
5. Position the clamps appropriately on the panel seam. Using a 3/16" allen-wrench attachment tip for a 1/4" drive screw gun, tighten and retighten set screws as the seam material compresses. (These screw gun tips are available from your S-5! product distributor). On low seam profiles, a 4" bit extension on the screw gun will facilitate this work. Most industrial grade screw guns are rated at 115 inch-pounds tightening torque and will deliver between 115 and -lbs (13-17Nm) at the *highest torque setting*. Please see ultimate load table on the back of this page or attached page for proper screw tensions and caution notes for various panel seams.
6. **CAUTION:** Battery-operated guns may not deliver consistent screw tension. Drywall guns may not deliver adequate tension.
7. Insert the 1" o.d. tubing through the holes in the uprights.
8. See Pipe Coupling Installation instructions for installing the 1" o.d. tubing.

### II. Locking Collars, End Caps, and Ice Flags (optional)

1. Locking collars (#65 ) should be placed over each end of each line of tubing. Center the tubing on the snow guards and tighten the set screw on the collar until it no longer slips.
2. End caps (#56) are installed by pressing the cap into the end of the pipe.
3. Ice flags (#95 ), if used, should be placed over the top tube so that the long leg rests against the uphill side of both tubes. Use the carriage bolt and nut to hold the ice flag in position.

### III. Bracket Assembly – Below is an assembly detail for the #2000T2K brackets.

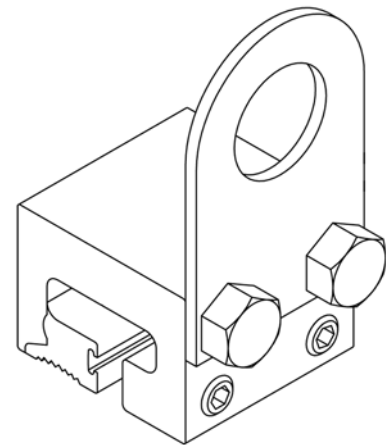

#### Snow guard Layout for Pipe Style Brackets

- \* Contact the manufacturer for detailed layout.
- \* Horizontal spacing between brackets should be 48" maximum. This may have to be decreased due to variable conditions.
- \* Do not install runs than 100 feet long without a break to allow for thermal expansion.
- \* First row of snow guards is installed above outer most wall or support of the building.
- \* Tubing is 1" O.D. aluminum.
- \* Brackets are made of aluminum and are available in other metals.
- \* One, two and three pipe systems are available.

The S-5! clamp is a handy gadget for a great many uses, but will not perform miracles. **PLEASE USE THIS PRODUCT RESPONSIBLY!** Any loads imposed on the S-5!clamp will be transferred to the panels. Panels must be adequately attached to building structure to resist these loads. For critical installations, inquire for specific test data of ultimate tensile load on specific panel materials and seam types. When tabled values are used, screw tensions should be verified and factors of safety should be used as appropriate. The manufacturer expresses no opinions as to the suitability of the S-5! for any specific application or project condition.

**ALWAYS PROVIDE WORKER FALL PROTECTION WHEN INSTALLING S-5!. THE S-5! CLAMP IS NOT APPROVED FOR USE AS A PERSONAL FALL RESTRAINT DEVICE**

Copyright © 2007, Metal Roof Innovations, Ltd.

## #2000T2K One-Pipe Clamp to the Seam Snow Guard for Standing Seam Metal Roofs