



**#015 One Pipe Snow Guard for Membrane Roofs**

NOTES;

1. SNOW GUARDS TO BE INSTALLED ACCORDING TO MANUFACTURER'S SPECIFICATIONS.
2. DO NOT SCALE DRAWINGS.
3. CONTACT MANUFACTURER FOR DETAILED LAYOUT.
4. PRODUCTS MAY VARY FROM ILLUSTRATION.

| REVISIONS |                        |           |
|-----------|------------------------|-----------|
| REV.      | DESCRIPTION            | DATE      |
| A         | CHANGE BASE PLATE SIZE | 3/12/2008 |

- |  |  |
|--|--|
| <input checked="" type="checkbox"/> CONFIGURATION          | <input checked="" type="checkbox"/> MATERIAL |
| <input checked="" type="checkbox"/> 1 PIPE (SHOWN)         | <input checked="" type="checkbox"/> ALUMINUM |
| <input checked="" type="checkbox"/> PIPE SYSTEM COMPONENTS | <input checked="" type="checkbox"/> FINISH   |
| <input checked="" type="checkbox"/> PIPE                   | <input type="checkbox"/> MILL (STANDARD)     |
| <input checked="" type="checkbox"/> END CAPS               | <input type="checkbox"/> POWDER COATED       |
| <input checked="" type="checkbox"/> END COLLARS            | <input type="checkbox"/> RAL: # _____        |
| <input checked="" type="checkbox"/> COUPLINGS              |  |
| <input type="checkbox"/> ICE FLAGS (OPTIONAL)              |  |
| <input type="checkbox"/> ICE SCREEN (OPTIONAL)             |  |

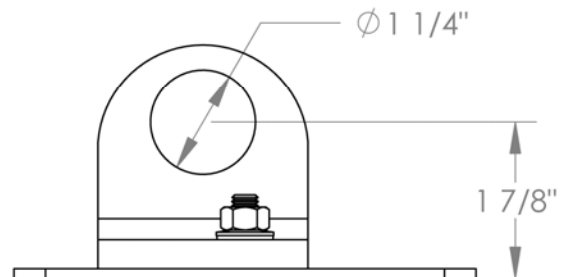
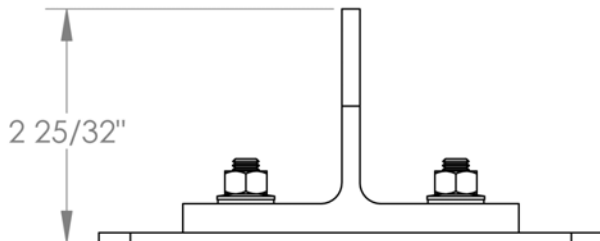
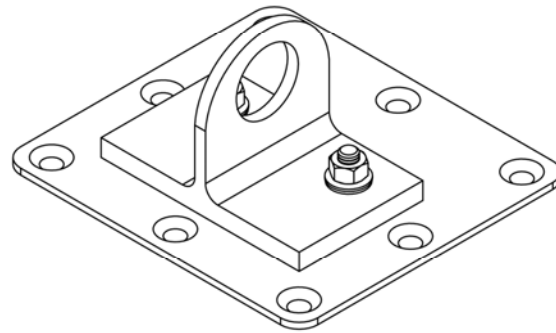
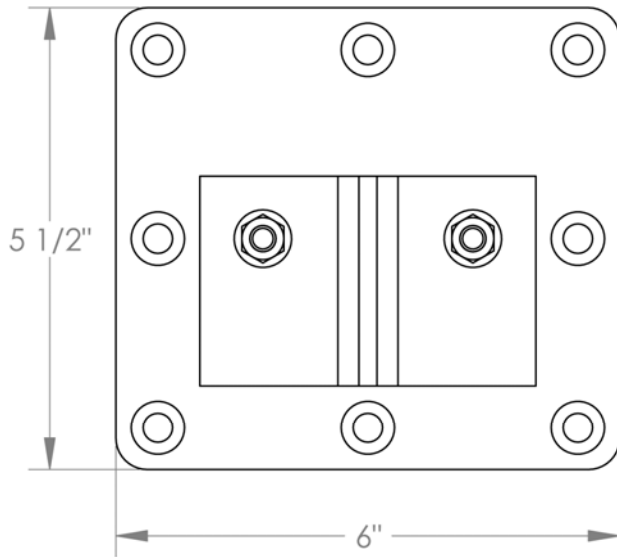

**#015 Pipe-Style Snow Guard for Membrane Roofs**

## #015 Pipe-Style Snow Guard Specification Sheet

### PART 1 – GENERAL

#### 1.1 SUMMARY

##### A. WORK INCLUDES

1. #015 Snow guard that attaches directly to the roof deck.
2. Provide appropriate snow guard and fasteners for the roof system.

##### B. RELATED SECTIONS

1. Section 07600: Flashing and Sheet Metal MasterFormat™ 2004 07 60 00
2. Section 07500: Membrane Roofing MasterFormat™ 2004 07 50 00
3. Division 7: Thermal and Moisture Protection.

#### 1.2 SYSTEM DESCRIPTION

##### A. COMPONENTS:

1. #015 Snow guard system consists of snow guard bracket and base plate
2. Tubing (snow rails).
3. Couplings.
4. End Caps (optional).
5. End Collars (optional).
6. Deck Fasteners
  - a. To be of metal compatible with snow guards.
  - b. Fasteners should be selected for compatibility with the roof deck.
  - c. Fastener strength should exceed or be equal to that of the snow guard system.
7. Adhesive: to be membrane roof manufacturer approved.

##### B. DESIGN REQUIREMENTS:

1. Spacing to be recommended by manufacturer or building engineer.
2. A minimum of 8 fasteners per snow guard base plate.
3. It is important to design new structures or assess existing structures to make sure that they can withstand retained snow loads.

#### 1.3 SUBMITTAL

- A. Submit manufacturer's specifications, standard detail drawings, recommended layout and installation instructions.

#### 1.4 QUALITY ASSURANCE

- A. Installer to be experienced in the installation of specified roofing material and snow guards for not less than 5 years in the area of the project.

#### 1.5 DELIVERY / STORAGE / HANDLING

- A. Inspect material upon delivery and order replacements for any missing or defective items. Keep material dry, covered and off the ground until installed.

---

## #015 Pipe-Style Snow Guard for Membrane Roofs

---

## **PART 2 - PRODUCTS**

### **2.1 MANUFACTURER**

- A. Alpine SnowGuards. A division of Vermont Slate & Copper Services Inc, 289 Harrell St, Morrisville VT (888) 766-4273, www.alpinesnowguards.com.

### **2.2 MATERIALS**

- A. Snow guard component is extruded and milled 6061-T6 Aluminum
- B. Base Plate is 11 gauge (1/8") thick; (choose one)
  - 1. 302 or 304 Stainless Steel.
  - 2. Steel, 1018 alloy, mild steel.
- C. Tubing is 6061-T6, 1" outside diameter and 1/8" wall thickness extruded Aluminum.
- D. Couplings are 2011 Aluminum 3" long.
- E. End Caps are 302 stainless steel.
- F. Ice Flaps are 5052-H32 Aluminum 3" x L (as needed).
- G. End Collars are 6061 T-6 aluminum shaft collars.
- H. Nuts and bolts for base plate to snow guard base are 304 Stainless Steel with an 18-8 finish.

### **2.3 FINISH**

- A. All base plate materials (concealed below flashing) provided mill finish.
- B. Bracket Finish:
  - a. Mill Finish
  - b. Powder coated

## **PART 3 - EXECUTION**

### **3.1 EXAMINATION**

- A. Substrate: Inspect roof system to be properly attached and installed to withstand additional loading incurred. Notify General Contractor of any deficiencies before installing Alpine SnowGuards.

### **3.2 INSTALLATION**

- A. Comply with architectural drawings for location and with Manufacturer's instructions for installation and recommended layout.

---

## **#015 Pipe-Style Snow Guard for Membrane Roofs**

## #015 Pipe-Style Snow Guard for Membrane Roofs Assembly Instructions

### I. Base Plate (The base plate is the flat piece with the two threaded studs.)

- A Continuous block is required underneath the membrane roof surface to attach the base plate. This base flange is 8" long and 6" wide. Mounting this system over insulation alone may crush the insulation and cause the roof to leak.
- Place the base plate on top of the finished membrane roof. NOTE: The threaded studs on the base plate are not centered. For #115 installation, align the base plate so that the studs are on the up-slope end of the base plate.
- Before fastening base plate through membrane to mounting block below, apply a generous amount of acceptable sealer under the flange.
- Consult with manufacturer, project engineer or fastener company to determine the fastener required to attach the base plate to the wood block. See test information for assistance.

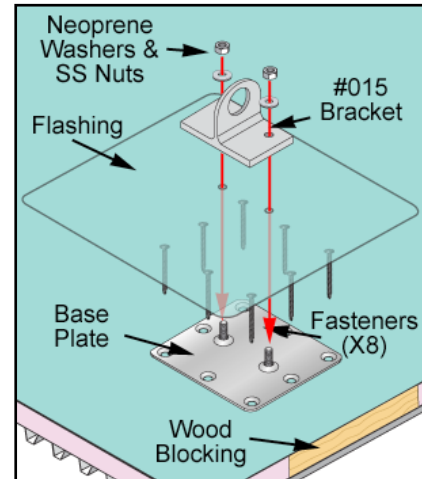

### II. Membrane Flashing of Base Plate

- Use an Alpine SnowGuards membrane patch or an acceptable piece of flashing material 12" square.
- Cut two small holes in membrane flashing to fit tightly over threaded studs.
- Before installing flashing apply a generous amount of acceptable sealer around threaded studs.
- Apply flashing over base plate using proper mastics or installation techniques so as to create a water tight patch.
- The threaded studs are now the only part of the base plate exposed. NOTE: Due to the sealer applied around the studs there may be bleed out at this opening. When the snow guard block is installed over the studs and tightened this bleed out will help to create a water tight compression fitting.

### III. Installation of snow guard block

- Install snow guard block over threaded studs. The Block will be centered on the base plate when installed properly.
- Place one neoprene bonded washer over each stud.
- Place locking nut over neoprene bonded washer and tighten.
- Insert tubing through the holes in the uprights.

### IV. Locking Collars, End Caps, and Ice Flags (optional)

- Locking collars ( #65 ) should be placed over each end of each line of tubing. Center the tubing on the snow guards and tighten the set screw on the collar until it no longer slips.
- End caps ( #56 ) are installed by pressing the cap into the end of the pipe.
- Ice flags ( #95 ), if used, should be placed over the top tube so that the long leg rests against the uphill side of both tubes. Use the carriage bolt and nut to hold the ice flag in position.

See the Pipe Accessories Installation document for more information.

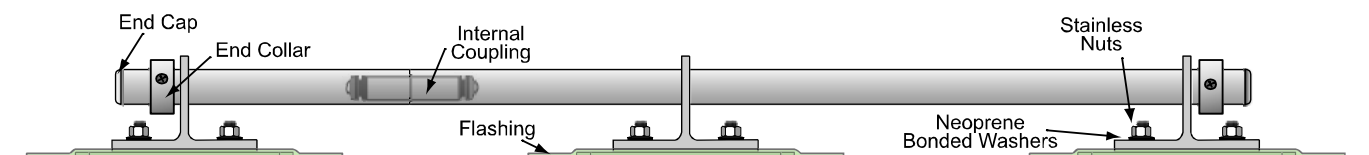

## #015 Pipe-Style Snow Guard for Membrane Roofs